

Pascal Stang  
 Procyon Engineering

Title  
 LightNAV System - Interface and Power

Size B Document Number 2002-08-22-0002 Rev A

Date: Thursday, September 05, 2002 Sheet 1 of 5

DIGITAL IR RECEIVERS:  
 PANASONIC PNA4602M  
 SHARP GP1U5

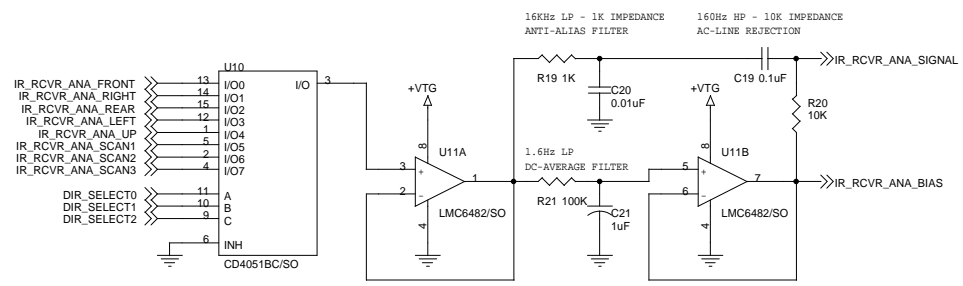
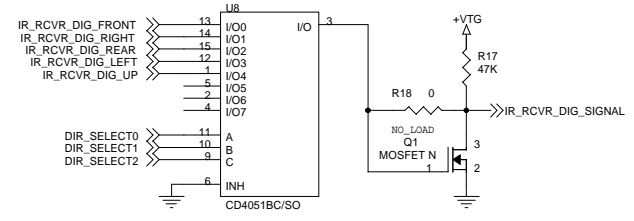
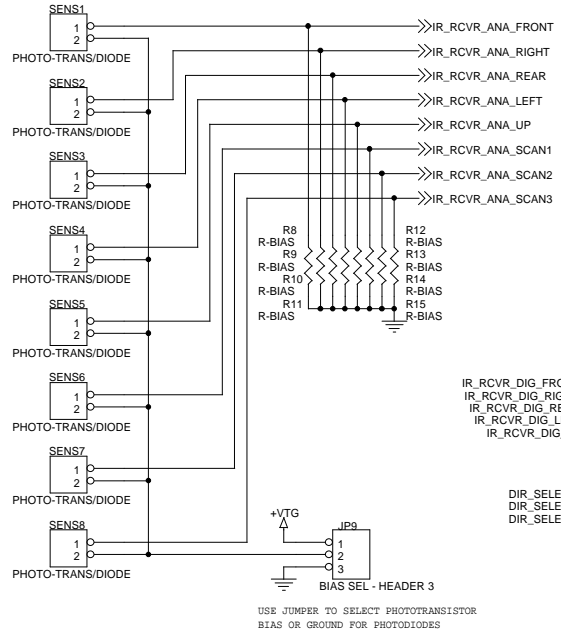
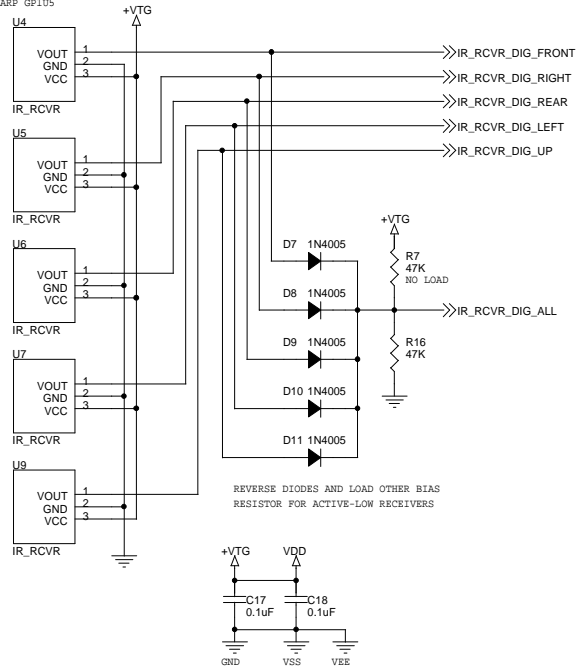

Pascal Stang Procyon Engineering		
Title LightNAV System - IR Sensors		
Size B	Document Number 2002-08-22-0002	Rev A
Date: Thursday, September 05, 2002	Sheet 2	of 5

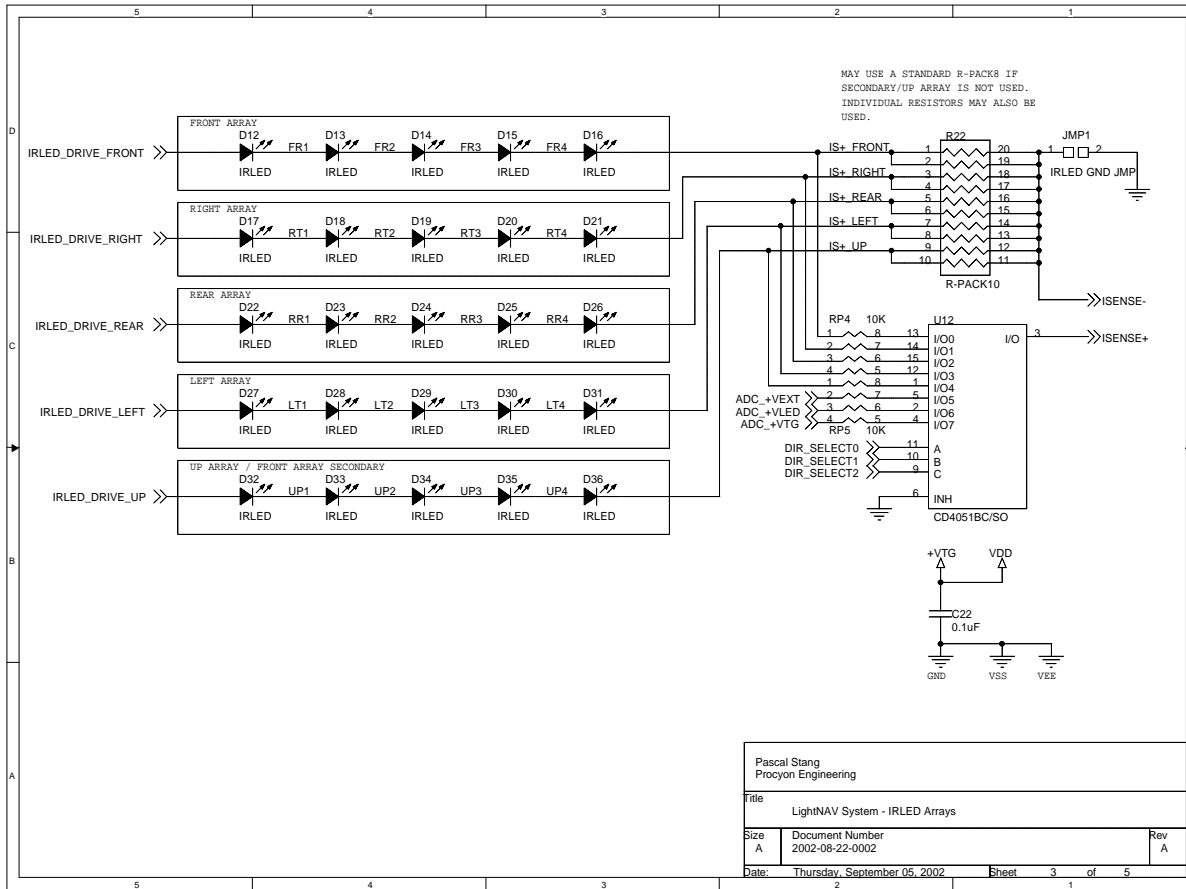

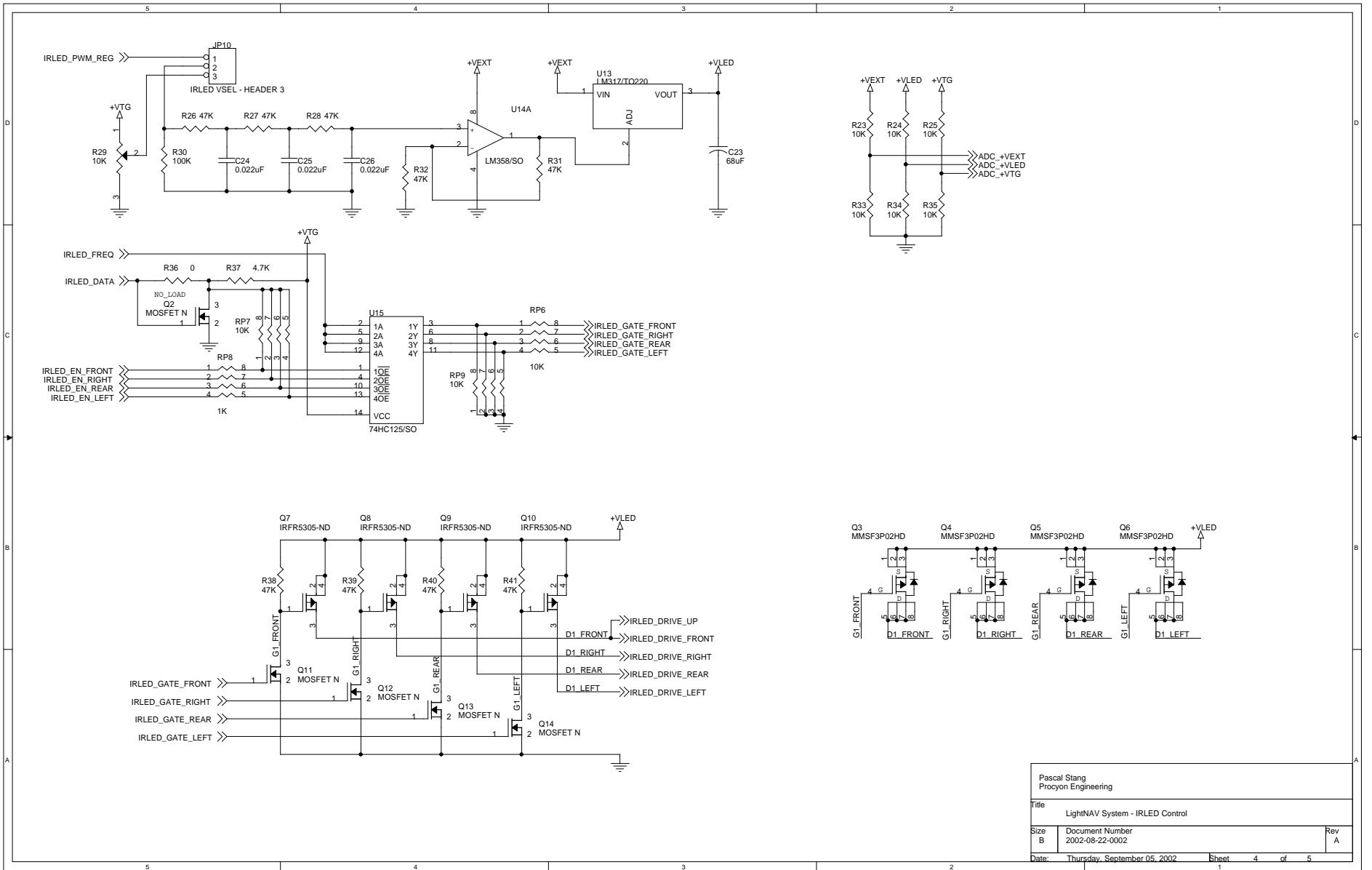

Pascal Stang  
 Procyon Engineering  
 Title: LightNAV System - IRLED Control  
 Size: B Document Number: 2002-08-22-0002 Rev: A  
 Date: Thursday, September 05, 2002 Sheet: 4 of 5

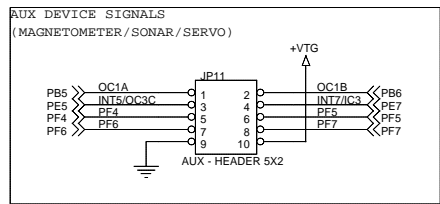
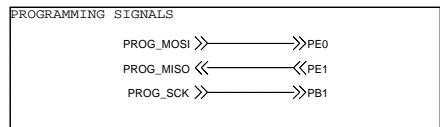
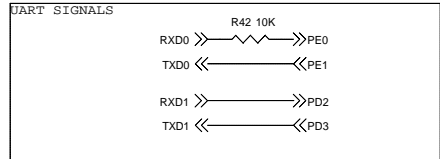
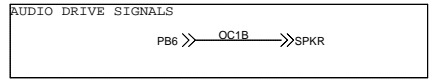
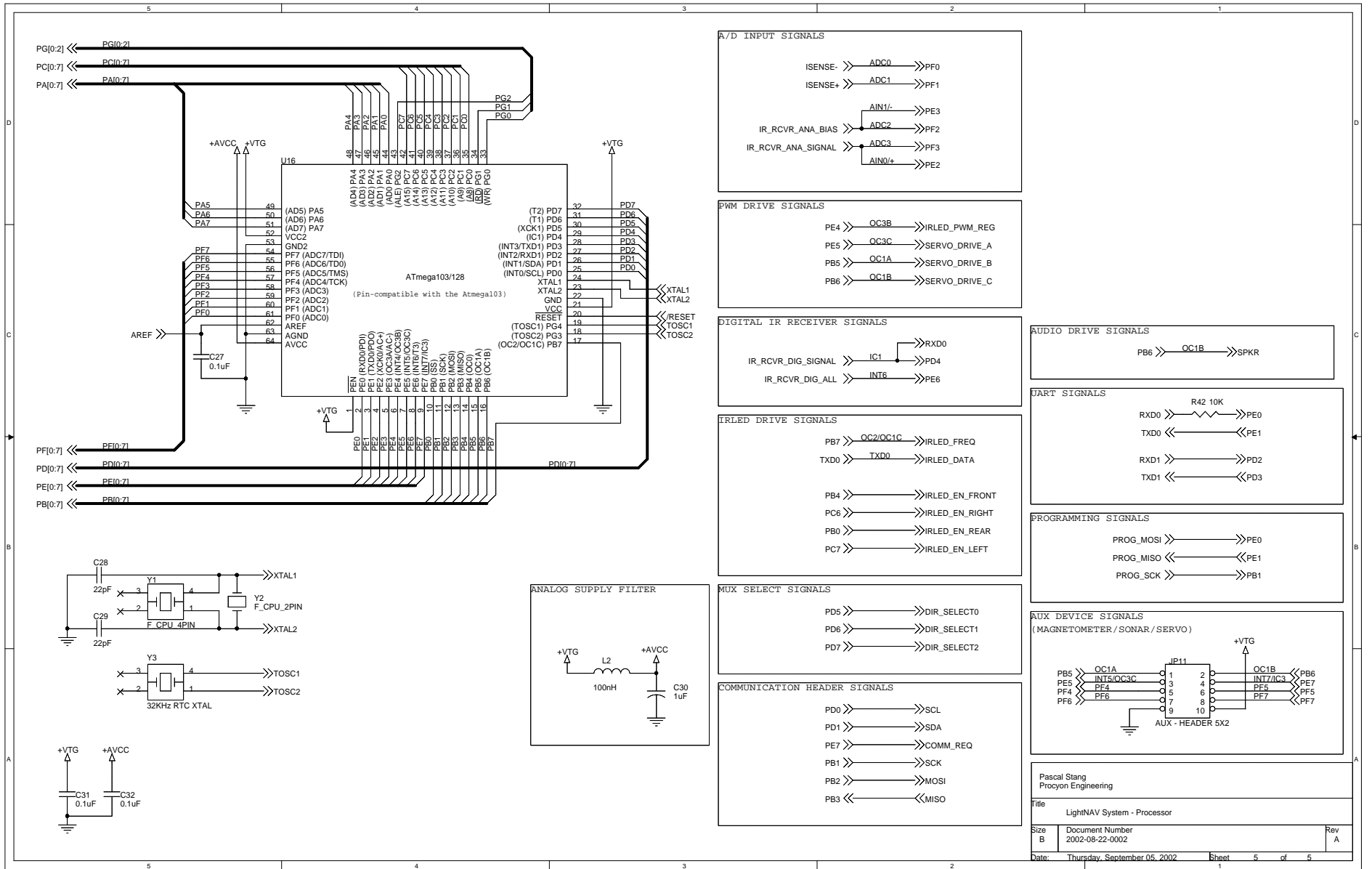

Pascal Stang  
Procyon Engineering

Title: LightNAV System - Processor

Size: B	Document Number: 2002-08-22-0002	Rev: A
---------	----------------------------------	--------

Date: Thursday, September 05, 2002 Sheet: 5 of 5